

Waste Water Aeration



Disc Diffuser

Tube Diffuser

Strip Diffuser



We are Jäger



Table of Contents

We are Jäger	2
35 Years of Innovation	4
Right Diffuser Selection	6
Aeration Solutions	
Disc diffuser	8
Tube diffuser	10
Strip diffuser	12
Performance Expectations	14
Customer Orientation	16
Development and Testing	18
Selected References	20

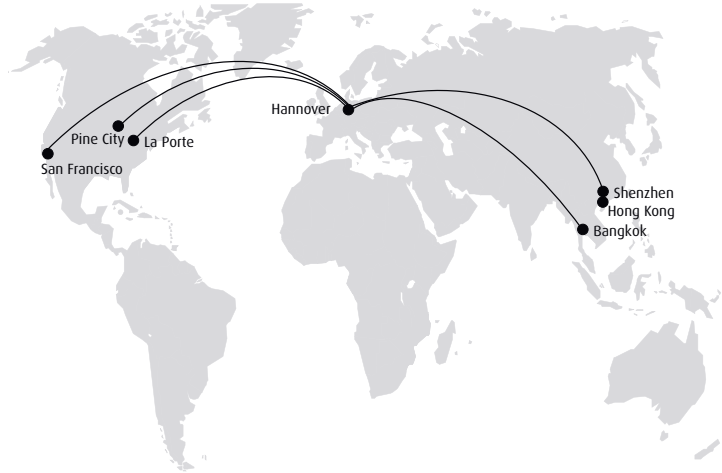

We grew up with rubber

Since 1942, when Gummi-Jäger, the parent company of Jäger Umwelt-Technik GmbH & Co. KG, was founded, application-oriented advisory service, material-oriented construction and system related development are the key for the Jäger Group's success.

Our competence and efficiency continuously raised according to the customers' demands. Our success is based on continuous product innovation, consulting independent from the material as well as a friendly, competent service and zero-defect philosophy competent service.

The family business in its third generation operates worldwide and is a qualified partner in the field of automotive, environmental and agricultural industry as well as in machine and plant engineering and oil exploration. Over 1.000 employees working in more than 20 sites in Europe, the USA and China aim to ensure that.

Our Philosophy

Thinking across departments and corporate boundaries as well as generating competitive advantages for one's own company, customers and suppliers: Due to these guiding principles the Jaeger Group of Companies is a professional partner in all branches of machine and plant engineering.

Confidence in Cooperation

Successful customer relationships are based on trust. For us, this means reliability in our promises and actions, fairness in equal partnership and the trustworthiness of the Jäger entrepreneur family.

Liability in partnership

Joint work with the most various suppliers guarantees competitive advantages for our customers.

Understanding in problem solution

By the combination of the most different materials and the integration of various functions in a system component we guarantee our customers a lasting advantage in competition.



35 Years of Innovation

Jäger. Rubber. Diffuser.

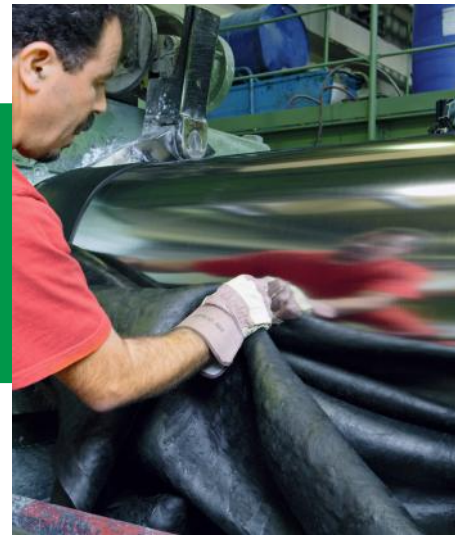

We are the original

At the beginning of the 1970's aeration systems did not longer meet the requirements of waste water treatment entirely. 35 years ago Arnold Jäger developed cooperating with the leading German wastewater treatment plants the first rubber membrane diffuser. Since that time, the innovative rubber EPDM-membrane diffusers save energy and processing costs.

Since 1975, Gummi-Jäger produced more than 20 Million membranes and diffusers for the leading manufacturers of waste water companies all over the world. During the last three decades, Arnold Jäger and his sons took out more than 30 patents on aeration technology in Europe and the USA.

The development team of the Jaeger Group of Companies perpetually works to improve the aeration technology. In order to meet the growing importance in the field of aeration systems, all Jäger activities concerning waste water treatment have been transferred to Jäger Umwelt-Technik GmbH & Co. KG in 2007.

- Our core competence is providing unique aeration solutions for biological wastewater treatment.
- Our success is based on continuous product innovation, friendly, competent service and zero-defect philosophy.

Well-engineered

The used materials and production processes reflect our decades of experience. JetFlex® diffusers' performance data fulfill all essential requirements. Due to the broad range of accessories our JetFlex® diffusers can be installed onto any available aeration grid by replacing. Our JetFlex® diffusers are sustainably produced in large numbers and thus are available off-the-shelf. Therefore, we can quickly and reliably provide the required quantities even for great projects.

Customized and innovative

In addition to our standard product range we implement our customers' ideas and demands into tailor-made membranes and diffusers. Many renowned waste water companies effectively use our experience with waste water resistant materials, innovative production technology and complete quality control. In that way they benefit from distinctive energy efficient designs and, thus, produce sustainably competitive advantages. We enable our customers to comply with almost every effluent specification and project-specific life cycle cost requirements. State of the art engineering tools (CAD, CAM, FEA), in house medium scale testing and evaluation facilities and the close cooperation with research organizations as the Leibniz University of Hannover or the German Institute for Rubber Technology (DIK) ensure further continuous improvement and innovation.

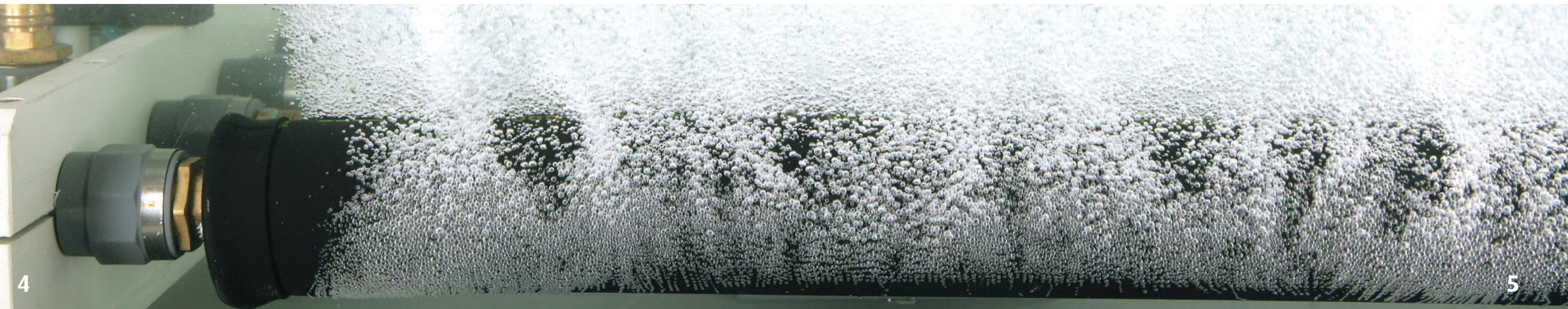

Diffuser Selection

Application engineering.



Requirements for tender compliance

For every application we offer the right tailor-made solution. Whether municipal or industrial systems, at reasonable costs or high efficiency, easy to use or especially for most demanding requirements – every diffuser has a certain field of application.

Considering the projects data and the analysis of the requirements profile we generate the overall cost analysis with regard to:

- Type of wastewater, waste water constituents, temperature and chemical characteristics
- Process engineering: low load / high load, conventionally / fixed bed, activated sludge / turbid water / aerobic stabilization
- Specific operational costs: energy costs, maintenance and service costs
- Evaluation of operational safety, different services and service intervals

The analysis of investment, maintenance and processing costs defines the specific requirements profile for the aeration system and enables the right choice.

Furthermore, a life-cycle-analysis over a sufficiently long period of time (15 – 25 years) allows to choose the optimum aeration system including air compressor and all pipe-work.



Aeration Solutions

Disc diffuser.



JetFlex® HD disc diffuser (HD-Series)

The Jäger HD disc diffuser series combines cost effective design, low installation costs, reliability and performance in intermittent and continuous aeration processes. HD disc diffusers additionally offer a wide range of advantages:

- Precise die cut openings for high oxygen transfer efficiency and low head loss: According to system specifications as well as customer demands we offer different slit patterns varying in number and length of the slits and the spacing between the slits.
- Active diameter between 184 mm and 295 mm
- Various standard and special membrane materials provide a wide spectrum of applications. EPDM, silicone, polyurethane, nitrile, Viton® are available.
- Additionally, EPDM membranes can be coated with Original Teflon® made by DuPont.
- Glass fiber reinforced plastics for maximum chemical and thermal resistance
- Non-return valve is optionally available

- Various connections for plastic and steel tubes due to comprehensive range of accessories
- Long maintenance intervals
- Standard diffusers available in stock

ECO-JUT AT 420 (AT-Serie)

For systems that require a small number of pipe-work, the ECO-JUT AT 420 is the appropriate application. These up-to-date high-performance diffusers possess unique properties:

- High SOTE rates at low head losses
- Intensive mixing of activated sludge ensured due to airlift effect
- High economic efficiency of aeration at considerable air-flow rates per diffuser - capacity of one diffuser ECO-JUT AT 420 is equal to capacity of several conventional disc diffusers

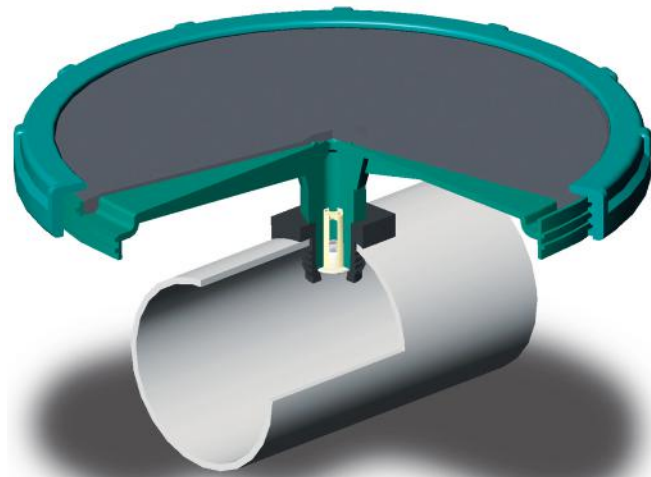

JetFlex® HD

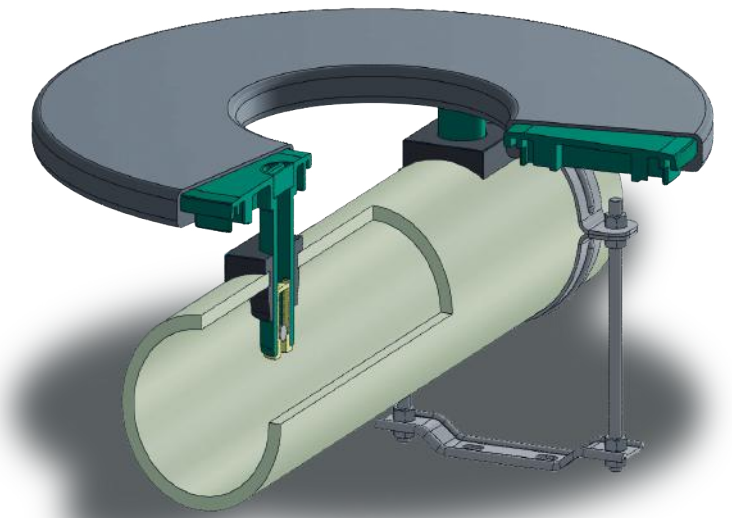

ECO-JUT AT 420



Aeration Solutions

Tube diffuser.



JetFlex® TD tube diffuser (TD-Series)

The Jäger TD tube diffuser series also combines cost effective design, low installation costs, reliability and performance in intermittent and continuous aeration processes. TD tube diffusers additionally offer a wide range of advantages:

- Precise die cut openings for high oxygen transfer efficiency and low head loss: According to system specifications as well as customer demands we offer different slit patterns varying in number and length of the slits and the spacing between the slits
- Low head loss due to grooved PP-support tube
- Active length from 200 - 1200 mm with standard length of 500 mm, 750 mm and 1000 mm

- Mounting resp. assembling possible onto round and square tube headers
- Different standard and special membrane materials provide a wide spectrum of applications. EPDM, silicone, polyurethane, nitrile and Viton® are available.
- Additionally, EPDM membranes can be coated with Original Teflon® made by DuPont
- Further materials are available upon request
- A comprehensive range of accessories allows to additionally equipping the systems of all leading competitors

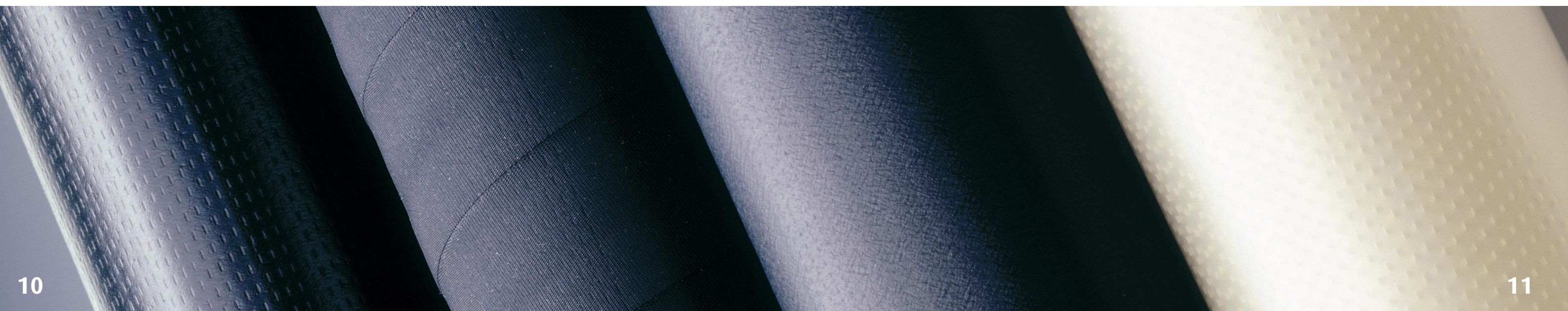
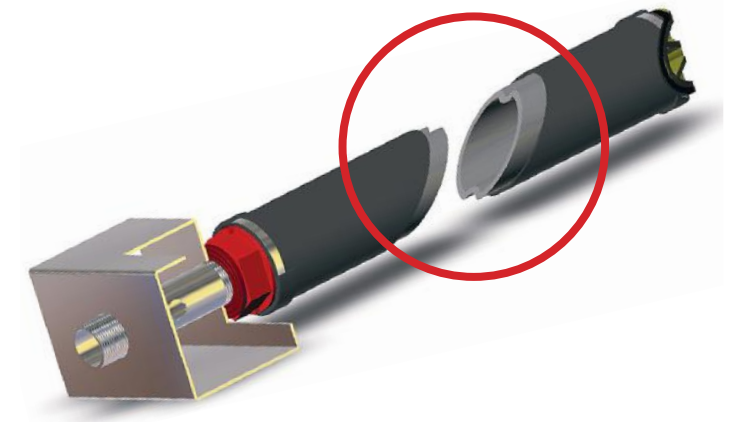

Aeration Solutions

Strip diffuser.

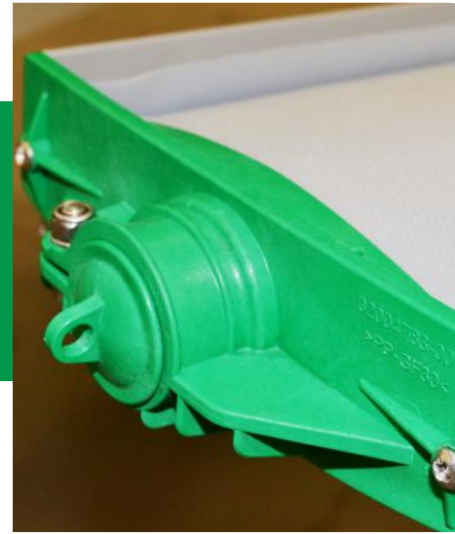

JetFlex® SD strip diffuser (SD-Series)

The diffuser series SD completes Jäger's line of diffusers and continues our success story.

Energy efficiency due to micro perforation

The high-tensile micro-perforated polyurethane membrane guarantees maximum lifetime. Constructing the fixing devices we attached value on a membrane that does not show any signs of wear, even after many years of stress cycles.

By combining the two standard lengths 1.500 mm and 2.000 mm several diffuser lengths up to 6,0 m can be realized in gradations of 500 mm. Moreover, one port can provide enough air for up to 8,0 m length of diffusers including energy efficiency and low membrane load.

The innovative fixing plate even allows the connection of two diffusers. This stable fixture fulfills any requirement: installed directly on the floor, adjustable in height or set on a sub-construction. Anything goes with just one plate.

The new air connection concept needs no further sealants. The integrated sealing by O-ring allows the air tube easily to plug-in and to tighten-up. The simple and reliable fixation avoids complex and expensive installation work. The specifically developed non-return valve protects the diffuser from water and mud and simultaneously enables considerate relief of the membrane.



Performance Dedication

Delivering values.

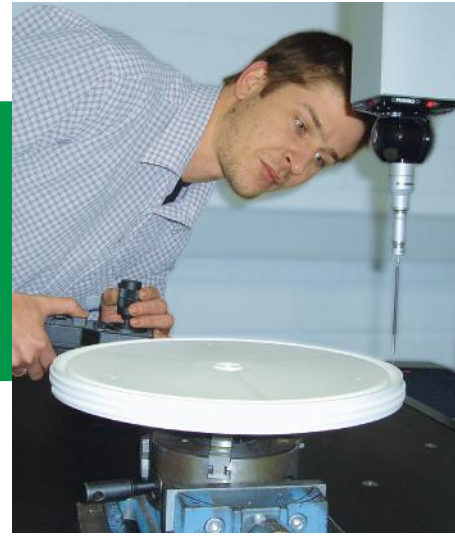

- We, the Jäger Umwelt-Technik, regard ourselves as development partner and supplier for aeration components and systems.
- We traditionally provide complete tube and disc diffusers as well as single certified components.
- Additionally, we cover whole aeration tanks up to the upper edge of the basin.
- Cooperating with system partners we provide further solutions for biological systems and treatment plants made by one source.

- We support partners in integrating systems and choosing components.
- We meet service specifications and bid for tenders.
- We guarantee customer's protection over competitors for all our customers, provided the projects are clearly identified.
- We commit to maintain confidentiality of any customer-specific know how

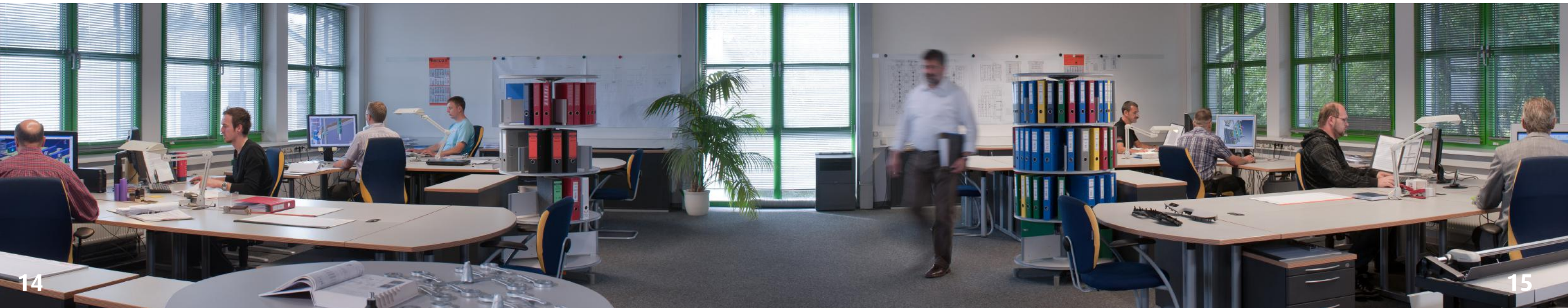

Customer Orientation

Successful cooperation.



Professional partners

Today we market our products in cooperation with more than 140 individual marketing and engineering partners. Therefore, we provide all necessary knowledge and technical experience in forms of complex documentations for our partners.

- Tables of materials
- Design programs
- Data sheets / performance specifications of the products
- Complex range of accessories
- Installation instructions
- Preventive maintenance
- Case studies / reference facilities all over the world

Our partners combine Jäger diffusers with their own regional know-how and own components, for example, compressors, pipe work, agitators and fixed beds.

Proven solutions

We provide verifiably cost efficient and long-life aeration solutions for the most challenging applications. In close cooperation with leading waste water OEM customers we developed a broad variety of:

- Waste water resistant rubber or polyurethane materials
- Membrane shapes and sizes
- Diffuser platforms
- Clamping mechanisms

Product and process quality

Jäger diffusers are manufactured in our sites in Germany, China and the USA. Processes in our production sites are certified and meet requirements according to DIN EN ISO 9001 and DIN EN ISO 14001. In our global production network we control the entire manufacturing process chain. All manufacturing and test data are recorded for traceability:

- Compound mixing
- Rubber molding and extrusion
- Plastics injection molding of the support bodies
- Final assembly of the components
- Head loss and bubble pattern testing during the whole production
- Durability testing in a 6 m deep tank



Development and Testing

Continuous improvement.



Material development

The diffusers' durability and functionality significantly determine the purification efficiency of a waste water treatment plant. Thus, we develop the materials for our diffuser membranes on our own. In our in-house laboratory our polymer engineers test waste water resistant elastomer and polyurethane materials. The combination of the raw material is optimized for various types of waste water. In the last 35 years we primarily developed specific membrane materials for numerous different types of industrial waste water:

- EPDM for most domestic waste water in municipal treatment plants
- Nitrile and Urethane for high durability and efficiency in oily waste water applications
- Silicone based compounds for high temperature resistance and specified industrial facilities

- Fluoro- and other specialty polymers for exceptional treatment processes

Our mixing facility automatically weighs up the raw materials. Internal mixers and rolling mills blend and homogenize the mixture. As a result, excellent and quality supervised basic material is available for further extrusion and injection moulding processes.

Application engineering

In standard version, the JetFlex® diffusers cover the most frequent demands. Our applications specialists give advice in choosing the appropriate membrane material according to waste water specifications. Furthermore, various perforation patterns are available in order to meet specific requirements of control range, volume flow

and oxygen injection. Being experts in manufacturing rubber and plastics we therefore develop customized membrane geometries, perforation patterns, plastic housings as well as air inlet assembly components for many suppliers of treatment technology. FEA-simulations and Rapid Prototyping support the design evaluation. Tooling concepts and product development are created parallel.

Laboratory testing and field tests

In our laboratory we systematically test prototypes and single units for mechanical strength and head loss performance in clean water. As part of regular audits we test the JetFlex® diffusers' durability and material fatigue with up to 1 million cycles. Furthermore, we cooperate with external partners, for example, Leibniz-University Hannover, Tongji University Shanghai/VR China,

German Rubber Institute (DIK), Hanover/Germany, GSEE Inc, La Vergne /USA and many more. In case of applications with specific waste water substances we recommend conducting pilot studies. Diffusers made of different membrane materials are installed on a testing frame. After short contact the membrane's possible change can be seen; durability and longevity can be estimated. In addition, we offer to evaluate the residual life span of our diffusers for our customers. After dismantling single diffusers out of the filter bed we examine the head loss caused by potentially changing materials and deposits. In that way, we can estimate whether a chemical and/or mechanical cleaning can extend the diffusers' life time or it is rather economic to completely replace the diffuser.



Selected References



Konya, Turkey			
Performance	Capacity	Products	Operating since
200.000 m ³ /d	1.000.000 PE	12.720 diffusers, 9 inch	2009



Chile			
Performance	Capacity	Products	Operating since
21.600 - 288.000 m ³ /d	54.000 - 720.000 PE	JetFlex TD	2011



Kedzierzyn-Kozle, Poland			
Performance	Capacity	Products	Operating since
22.000 m ³ /d	55.000 PE	2.400 TD63/2075 EPDM; 2.300 TD63/2075 Silicone	2003/2004; 2010/2011



Moscow, Russia			
Performance	Capacity	Products	Operating since
450.000 m ³ /d	1.125.000 PE	9.450 TOR diffusers with the membrane ECO-JUT AT 420	Autumn 2012



Sao Paolo, Brazil			
Performance	Capacity	Products	Operating since
57.600 m ³ /d	52.000 PE	832 EPDM diffusers membrane (Ø90x1000mm)	October 2012

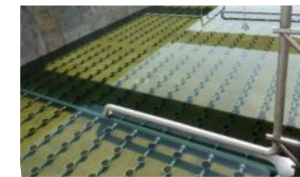

Buenos Aires, Argentina			
Performance	Capacity	Products	Operating since
170.000 m ³ /d	600.000 PE	2.650 Disc Diffuser with PVC support pipes in 4 Reactors	January 2012



Selected References

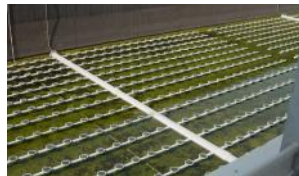

Abu Dhabi, UAE			
Performance	Capacity	Products	Operating since
40.000 m ³ /d	100.000 PE	5.620 Disc Diffuser HD 270	2009



Chantaburi, Thailand			
Performance	Capacity	Products	Operating since
3.500 m ³ /d	8.750 PE	1.484 Tube Diffuser TD63/2100	2012

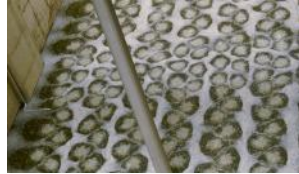

Seoul, South Korea			
Performance	Capacity	Products	Operating since
550.000 m ³ /d	1.375.000 PE	13.838 Disc Diffuser HD 270	2010



Ho-Chi-Minh-City, Vietnam			
Performance	Capacity	Products	Operating since
1.200 m ³ /d	3.000 PE	600 Disc Diffuser HD270	2012



Seoul, South Korea			
Performance	Capacity	Products	Operating since
550.000 m ³ /d	1.375.000 PE	14.634 Tube Diffuser TD 63×1000L	2010



Khanna Paper, India			
Performance	Capacity	Products	Operating since
20.000 m ³ /d	50.000 PE	1000 JetFlex HD 270 Disc Diffuser	2010



Jäger. Diffusers. Partners. Success.

We are material experts.

- For each waste water the appropriate material

We are specialists in aeration systems.

- For each plant the suitable aeration technology

We are engineers.

- For each customer the tailor-made product

We speak our customers' language.

- All over the world competent waste water experts on site



Jäger Umwelt-Technik GmbH & Co. KG
Ruscheplattenstraße 14
31137 Hildesheim

Phone: (+49) 5121 - 9138 900

Fax: (+49) 5121 - 9138 999

info@jaeger-envirotech.com

A Company of the Jäger Group of Companies.

The latest version of our brochure is available at: www.jaeger-envirotech.com.

